

halo double salon mirror

#8720

HALO DOUBLE MIRROR

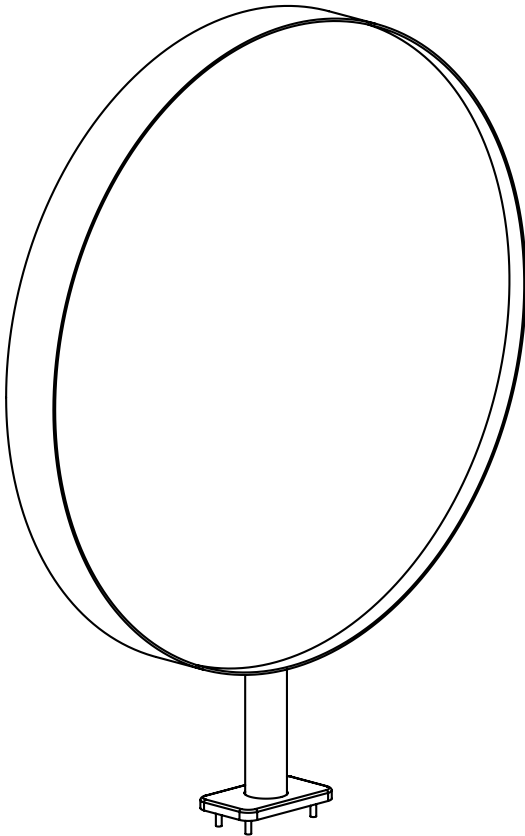



IMPORTANT PLEASE READ THESE SAFETY INSTRUCTIONS

GENERAL SAFETY

1. Read carefully and keep these instructions in a safe place.
2. Use this product only for its intended function and do not use attachments not recommended by the manufacturer.
3. Do not use outdoors.



WEIGHT: 15kg
33lbs

GET STARTED

All measurements are in MM (inches)

HALO DOUBLE

Double Mirror for a Free Standing Station

Weight: 15Kg (33lbs)

Material: Chrome Brass Finish

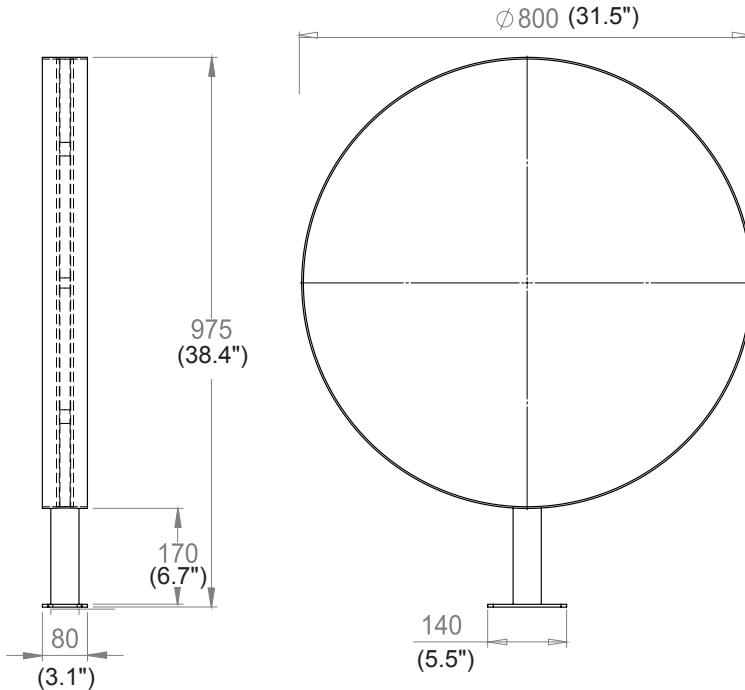

A	B	C	D
1PC	M6x40 4PCS	4PCS	8PCS

FIXINGS INCLUDED:
1X M6X25 SCREW
4X M6X40 HEX BOLT
4X M6 NUT
8X M6 WASHER

INSTALLATION: MOUNTING

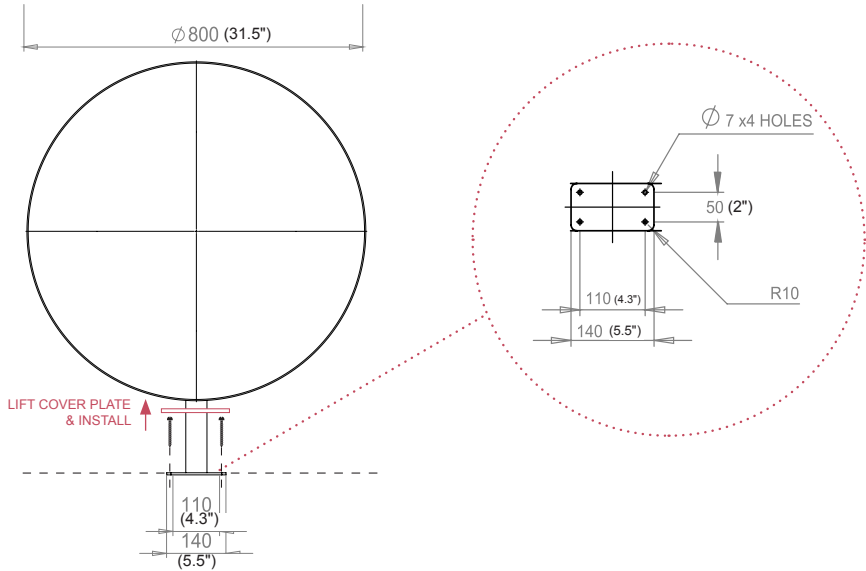

BEFORE INSTALLING YOU SHOULD CONSIDER THE FOLLOWING:

Allow for the necessary room around the



PLEASE USE CORRECT FIXTURES FOR MOUNTING BASED ON BENCH TYPE. NO RESPONSIBILITY IS ACCEPTED FOR ANY DAMAGE OR INJURY CAUSED BY INCORRECT MOUNTING.

INSTALLATION: FREE STANDING TABLE SOLD SEPARATELY.

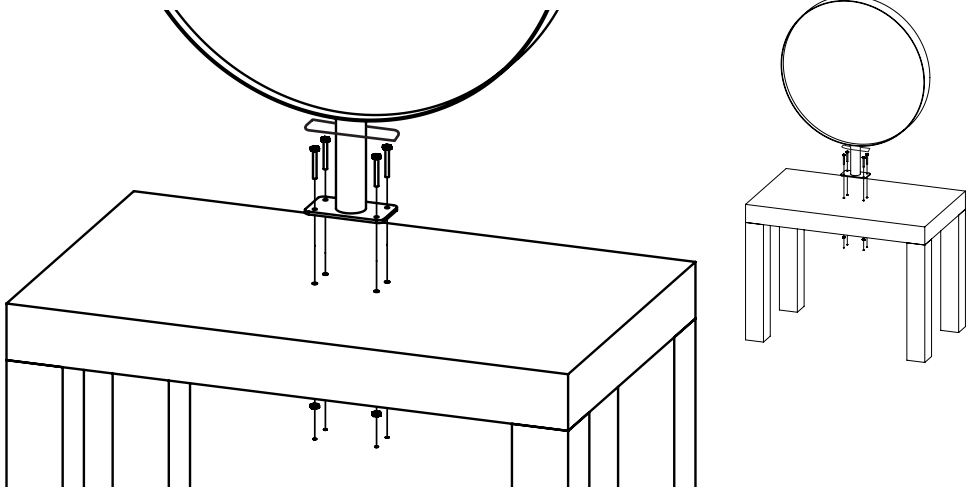

CLEANING

GENERAL CLEANING

- We recommend the use of soapy water or approved cleaners.
- This product should not be cleaned with abrasive materials.
- Damage caused by any improper treatment is not covered by the product warranty.

MAINTENANCE

A periodic inspection of all components and fasteners should be made to ensure that your Comfortel product is structurally intact and functioning properly.

Damaged and broken parts should be replaced and loose fasteners tightened.

All maintenance to be carried out by a suitably qualified tradesperson.

comfortel

help.comfortel.com.au

PRODUCT CODE

#8720 HALO DOUBLE

The information contained in this document is subject to change without notice and should not be construed as a commitment by Comfortel Furniture Pty Ltd.

Comfortel Furniture Pty Ltd. assumes no responsibility for any errors that may appear in this document nor does it make expressed or implied warranty of any kind with regard to this material, including, but not limited to, the implied warranties of merchantability and fitness for a particular purpose.

Comfortel Furniture Pty Ltd. shall not be liable for incidental or consequential damages in connection with or arising out of the use of this document and the program material.

©Comfortel Furniture. All rights are reserved. No part of this document may be photocopied, reproduced or translated to another language without written consent of Comfortel Furniture Pty Ltd.

PLEASE RETAIN THIS INFORMATION FOR FUTURE REFERENCE

For more information about our products and services, contact us at comfortel.com.au

WARRANTY PERIOD

TERMS AND CONDITIONS. For more information about our warranty, please refer to our website.

PURCHASE DATE

INVOICE NUMBER

NOTE YOUR PURCHASE DATE & INVOICE NUMBER FOR FUTURE REFERENCE