

luma pedestal base

#7626 LUMA PEDESTAL BASE

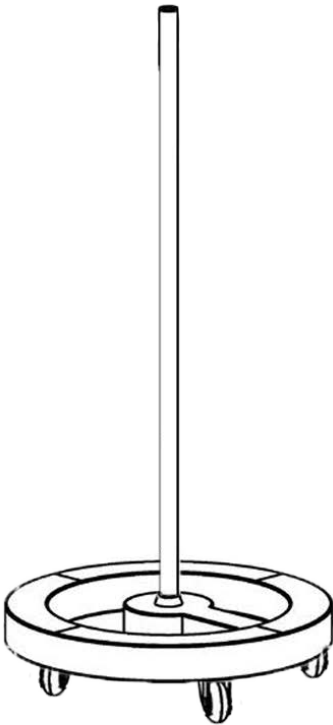

THIS PRODUCT IS INTENDED FOR
COMMERCIAL/PROFESSIONAL USE ONLY

ASSEMBLY

PARTS

1. Pole
2. Base
3. Wheels
4. Nut for fixing base

ASSEMBLY

1. Bolt the pole (1) onto the base (2) using the nut (4) and attach the wheels (3) to the base.

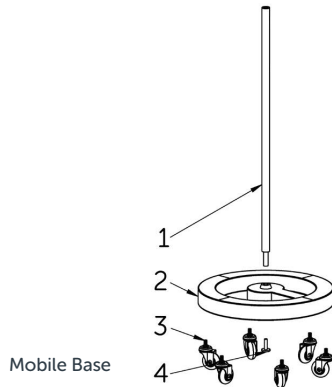

CLEANING

BEFORE CLEANING MAKE SURE THE LAMP IS DISCONNECTED FROM THE ELECTRICAL SUPPLY

The unit requires no special maintenance. If it becomes heavily soiled it can be wiped with a damp cloth containing a mild soap solution. Do not use large quantities of liquid as it may enter shade housing and affect electrical safety.

DO NOT USE ALCOHOL, SOLVENTS OR ABRASIVE CLEANERS, AS THEY WILL DAMAGE THE PLASTIC HOUSING.

IMPORTANT To clean the lens use a cotton cloth with warm soapy water or glass cleaner. Do not use abrasive cleaners, as they will damage the lens.

MAINTENANCE

A periodic inspection of all components and fasteners should be made to ensure that your product is structurally intact and functioning properly.

Damaged and broken parts should be replaced and loose fasteners tightened.

All maintenance to be carried out by a suitably qualified tradesperson.

comfortel

comfortel.com.au

PRODUCT CODE

#7676 LUMA LAMP PEDESTAL

SMD 48 LEDs. 20V DC 9W

Revision Date: 16.2.2017

©Comfortel Furniture 1997-2017. All rights are reserved.
No part of this document may be photocopied, reproduced or translated to another language without written consent of Comfortel Furniture Pty Ltd.

The information contained in this document is subject to change without notice and should not be construed as a commitment by Comfortel Furniture Pty Ltd.

Comfortel Furniture Pty Ltd. assumes no responsibility for any errors that may appear in this document nor does it make expressed or implied warranty of any kind with regard to this material, including, but not limited to, the implied warranties of merchantability and fitness for a particular purpose.

Comfortel Furniture Pty Ltd. shall not be liable for incidental or consequential damages in connection with or arising out of the use of this document and the program material.

PLEASE RETAIN THIS INFORMATION FOR FUTURE REFERENCE.

For more information about our products and services, contact us at comfortel.com.au

PURCHASE DATE

INVOICE NUMBER

NOTE YOUR PURCHASE DATE & INVOICE NUMBER FOR FUTURE REFERENCE