

luma LED magnifying lamp

#7622 LUMA MAGNIFYING LAMP LED - WITH TABLE LAMP
#7670 LUMA MAGNIFYING LAMP PEDESTAL
#7635 WALL BRACKET

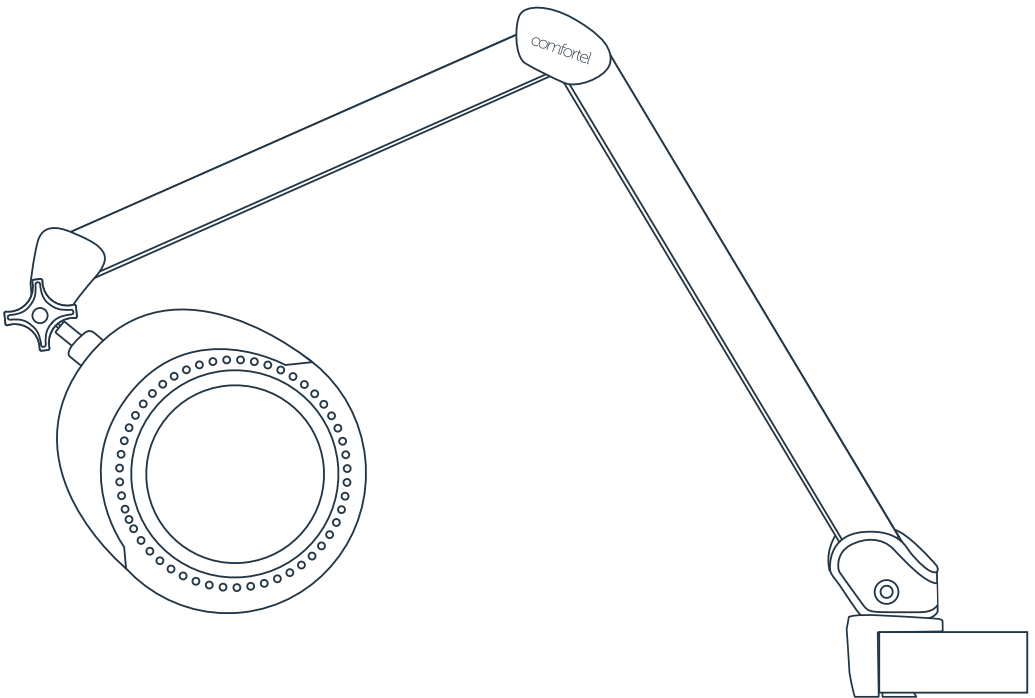

GET STARTED

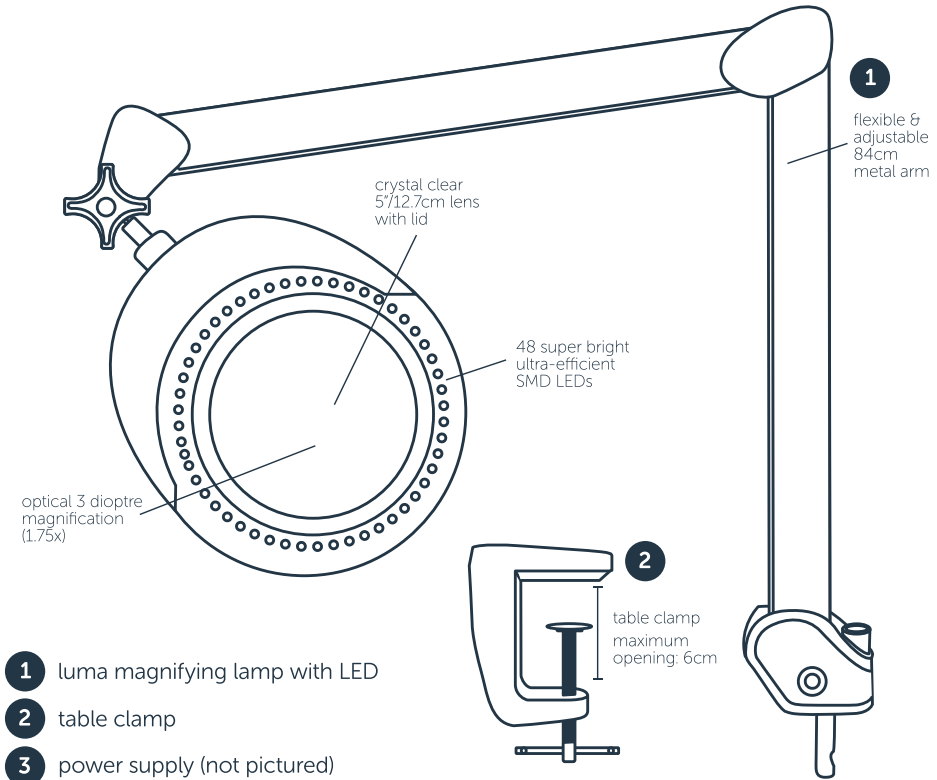

IMPORTANT PLEASE READ THESE SAFETY INSTRUCTIONS

GENERAL SAFETY

1. Read carefully and keep these instructions in a safe place.
2. Use this product only for its intended function and do not use attachments not recommended by the manufacturer.
3. Do not use outdoors.

PRECAUTIONS

1. The lamp should never be placed too close to the skin, or touching the skin.
2. Cover the client's eyes before positioning the lamp over the face.

CAUTION: WHEN ADJUSTING THE LAMP TAKE CARE NOT TO GET THE ELECTRICAL CORD TANGLED AROUND THE CLAMP OR LAMP STEM.

ELECTRICAL APPLIANCES

1. DO NOT allow children to operate in this product.
2. Turn the power off and remove the plug when not in use or when cleaning.
3. Do not let the power cord get damaged in any way.
4. Keep the power cord away from heat sources.
5. Do not use an extension cord unless the cord complies with local electrical safety standards.
6. Periodically inspect the power cord for signs of damage.
7. Do not operate any electrical item with a damaged power cord.

TABLE CLAMP: INSTALLATION & ASSEMBLY

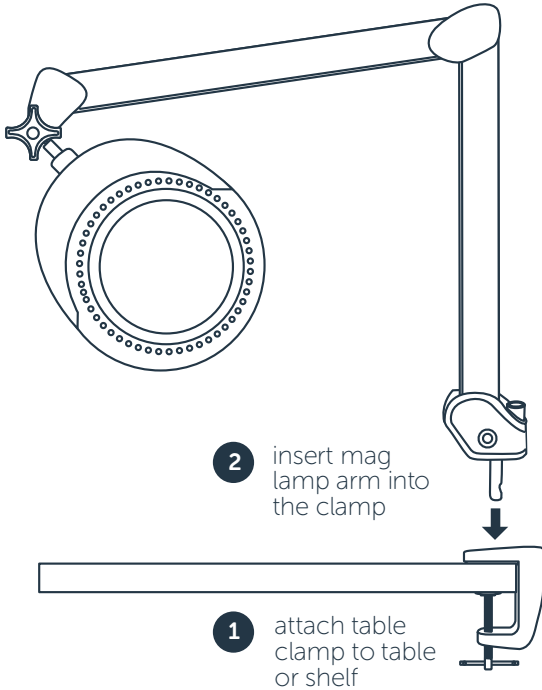

SET UP AND OPERATION

1. Before use remove all packaging from around the lamp.
2. Securely fasten the supplied table clamp onto the edge of a table or workbench.
Please Note: It is important that the table clamp is secure BEFORE attaching the lamp. If the supplied clamp does not meet your exact requirements, there is an optional Wall Mount or Pedestal available from Comfortel.
3. Once the clamp is secure insert the stem of the lamp arm into the hole in the clamp.
4. Insert the plug-in power supply into a conveniently located wall plug. The Luma Magnifying Lamp is now ready to use.
5. Switch on using the On/Off switch located on the head of the lamp.

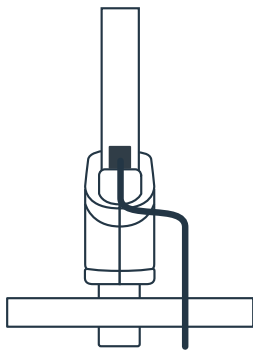

- 3 plug in power supply

- 4 turn LED light on via the mag lamp head

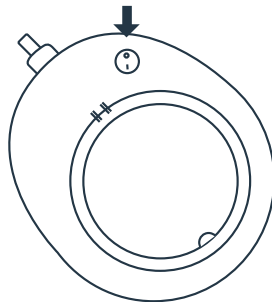

ULTRA-EFFICIENT LED'S

The Luma Mag Lamp is fitted with 45 LEDs which will last the lifetime of the lamp. No routines replacement is required.

CAUTION: Do not look directly at the lamp

LENS SAFETY

CAUTION: NEVER LEAVE THE LENS UNATTENDED IN DIRECT SUNLIGHT OR WHERE LIGHT CAN SHINE THROUGH. THIS CONSTITUTES A FIRE HAZARD. WHEN THE MAGNIFYING LAMP IS NOT IN USE, PLEASE REPLACE THE LENS COVER SUPPLIED.



CAUTION: DO NOT USE LAMP IF FLEXIBLE CORD IS DAMAGED

ANY REPAIRS TO LIGHT MUST BE CONDUCTED BY A QUALIFIED ELECTRICIAN.
TO REPAIR FLEXIBLE CORD, USE TWO CORE SHEATHED CABLE ONLY.

OPTIONAL: PEDESTAL BASE ASSEMBLY

PARTS

1. Pole
2. Base
3. Wheels
4. Nut for fixing base

ASSEMBLY

1. Bolt the pole (1) onto the base (2) using the nut (3) and attach the wheels (4) to the base.
2. Insert the stem of the lamp arm into the hole in the pole (1).
3. Insert the plug-in power supply into a conveniently located wall plug.
4. Switch on using the On/Off switch located on the head of the lamp.

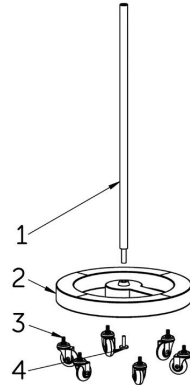

CLEANING

BEFORE CLEANING MAKE SURE THE LAMP IS DISCONNECTED FROM THE ELECTRICAL SUPPLY

The unit requires no special maintenance. If it becomes heavily soiled it can be wiped with a damp cloth containing a mild soap solution. Do not use large quantities of liquid as it may enter shade housing and affect electrical safety.

DO NOT USE ALCOHOL, SOLVENTS OR ABRASIVE CLEANERS, AS THEY WILL DAMAGE THE PLASTIC HOUSING.

IMPORTANT To clean the lens use a cotton cloth with warm soapy water or glass cleaner. Do not use abrasive cleaners, as they will damage the lens.

MAINTENANCE

A periodic inspection of all components and fasteners should be made to ensure that your product is structurally intact and functioning properly.

Damaged and broken parts should be replaced and loose fasteners tightened.

All maintenance to be carried out by a suitably qualified tradesperson.

comfortel

comfortel.com.au

PRODUCT CODE

#7622 LUMA MAGNIFYING LAMP LED
- WITH TABLE LAMP
#7670 LUMA MAGNIFYING LAMP PEDESTAL
#7635 WALL BRACKET

SMD 48 LEDs. 20V DC 9W

Revision Date: 16.2.2017

©Comfortel Furniture 1997-2017. All rights are reserved.
No part of this document may be photocopied,
reproduced or translated to another language without
written consent of Comfortel Furniture Pty Ltd.

The information contained in this document is subject to change without notice and should not be construed as a commitment by Comfortel Furniture Pty Ltd.

Comfortel Furniture Pty Ltd. assumes no responsibility for any errors that may appear in this document nor does it make expressed or implied warranty of any kind with regard to this material, including, but not limited to, the implied warranties of merchantability and fitness for a particular purpose.

Comfortel Furniture Pty Ltd. shall not be liable for incidental or consequential damages in connection with or arising out of the use of this document and the program material.

PLEASE RETAIN THIS INFORMATION FOR FUTURE REFERENCE.

For more information about our products and services, contact us at comfortel.com.au

PURCHASE DATE

INVOICE NUMBER

NOTE YOUR PURCHASE DATE & INVOICE NUMBER FOR FUTURE REFERENCE