

aquarius II treatment table

#6081

AQUARIUS II WHITE

#6082

AQUARIUS II BLACK

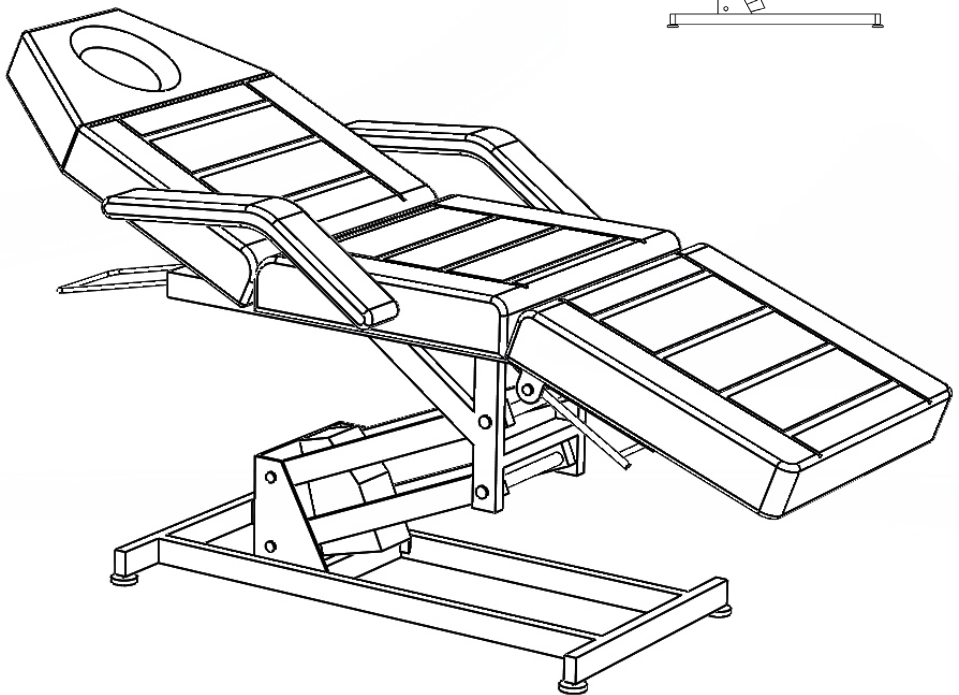
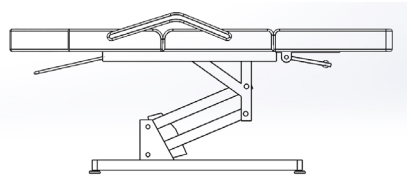



IMPORTANT PLEASE READ THESE SAFETY INSTRUCTIONS

Listed below are essential safety precautions.

GENERAL SAFETY

1. Read carefully and keep these instructions in a safe place.
2. Use this product only for its intended function and do not use attachments not recommended by the manufacturer.
3. Do not use outdoors.
4. Do not try to move the table when in use.

ELECTRICAL APPLIANCES

1. All GPO's must be installed by a qualified Electrician in accordance with local electrical standards.
2. DO NOT allow children to operate the electric motors in this product.
3. Turn the power off and remove the plug when not in use.
4. Turn the power off and remove the plug when cleaning.
5. Do not let the power cord get damaged in any way.
6. Keep the power cord away from heat sources.
7. Do not use an extension cord unless the cord complies with local electrical safety standards.
8. Periodically inspect the power cord for signs of damage.
9. Do not operate any electrical item with a damaged power cord.



IMPORTANT

KEEP FINGERS AND HANDS AWAY FROM TABLE JOINTS UNDER THE TABLE



IMPORTANT

DO NOT ALLOW CHILDREN AROUND THE TREATMENT TABLE WHEN IN USE



IMPORTANT

DO NOT ALLOW CHILDREN TO OPERATE THE ELECTRIC MOTORS THAT MOVE THE TABLE



IMPORTANT

DO NOT USE AROUND WATER OR IN A WET ENVIRONMENT



IMPORTANT

WHEN REPLACING ANY PARTS OR ASSEMBLING THE TABLE, YOU MUST ENSURE THE TABLE IS RESTING ON ITS SIDE TO SAFEGUARD FROM CRUSH INJURY

GET STARTED

TOP VIEW FLAT POSITION

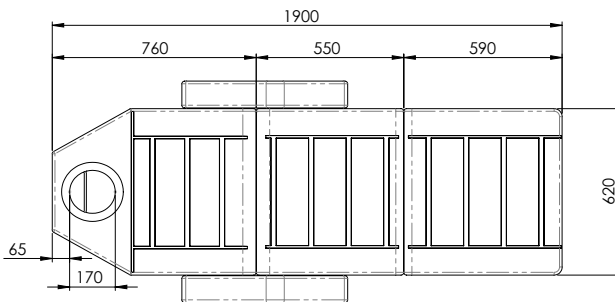

AQUARIUS II

Beauty bed with electric adjustment

Width: 640mm (830mm with arms)

Length: 1900mm

Height Range: 580mm-820mm

· Electric height adjustment

· Manual back & leg adjustment

· Foot control



OPTIONAL UPGRADE

BATTERY for back up power supply

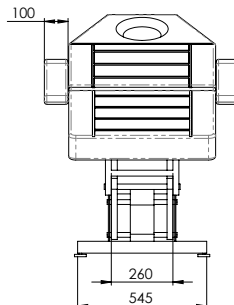
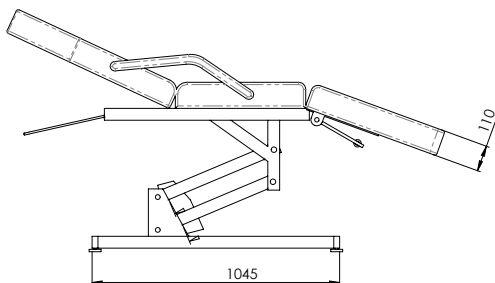

All measurements are in MM.

PARTS & ASSEMBLY

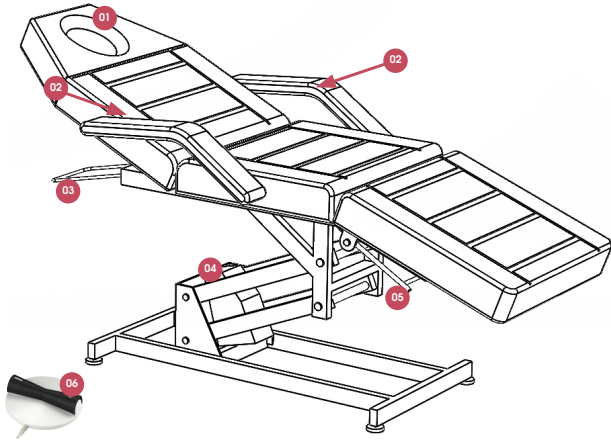

PARTS

1. Removable face plug
2. Removable arm rests
3. Lever to operate gas-lift back rest /Up/Down
4. Electric motor
5. Lever to operate manual leg rest /Up/Down
6. Foot control for height adjustment

ASSEMBLY

Comes fully assembled

OPERATION

FOOT CONTROL



Adjust the height range of the treatment table with the electric foot control.

1. - Moves the bed down
2. + Moves the bed up

FUNCTIONS

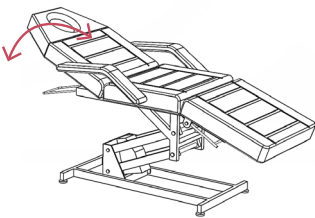

BACK ADJUSTMENT

Located behind the back, adjust the backrest up and down using the lever.

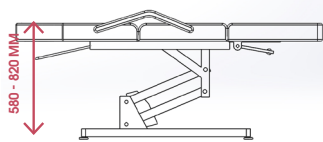

HEIGHT ADJUSTMENT

Using the foot control, adjust the table height by going up or down.

Minimum Height: 580mm

Maximum height: 820mm

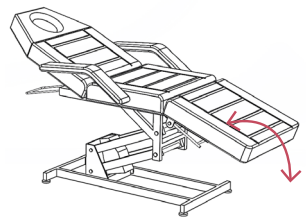

LEG ADJUSTMENT

Located under the leg area, slightly lift lever and move leg adjustment up or down and slot back into nominated groove.

MAINTENANCE

A periodic inspection of all components and fasteners should be made to ensure that your Comfortel Product is structurally intact and functioning properly.

Damaged and broken parts should be replaced and loose fasteners tightened.

All maintenance to be carried out by a suitably qualified tradesperson.

⚠ IMPORTANT
WHEN REPLACING ANY PARTS OR ASSEMBLING THE TABLE, YOU MUST ENSURE THE TABLE IS RESTING ON IT'S SIDE TO SAFEGUARD FROM CRUSH INJURY

CLEANING

UPHOLSTERY

All upholstery needs some care; good housekeeping will help to prolong the life of any upholstered products. Avoid extreme temperatures. Extreme cold can make your vinyl prone to cracking, while extreme heat can cause permanent stretching. Avoid exposing your products to direct sunlight for prolonged periods of time.

ALWAYS FOLLOW THE CLEANING INSTRUCTIONS

- Wipe with a clean colourfast cloth dampened with mild alkaline free soap and luke warm water. Do not wet excessively.
- Remove all traces of any cleaning product by wiping with fresh water and a clean cloth.
- Dry with a soft, clean cloth.
- Stubborn grime may require gentle scrubbing with a soft brush.

Do not use:

- hot or boiling water
- hydrocarbons including alcohol
- acetone
- furniture polishes
- bleach
- concentrated detergents
- abrasive powder or paste cleaners
- steel wool
- silicon or petroleum-based cleaners
- solvent based or abrasive cleaning agents

comfortel

help.comfortel.com.au

PRODUCT CODE

#6081 AQUARIUS II TREATMENT TABLE WHITE
#6082 AQUARIUS II TREATMENT TABLE BLACK

1 X 10AMP GPO REQUIRED
POWER: 240V, 50-60HZ, MAX 2.4A
MAX LOAD: 200KG (440lbs)

Revision Date: V3.1.09.2020

©Comfortel Furniture. All rights are reserved. No part of this document may be photocopied, reproduced or translated to another language without written consent of Comfortel Furniture Pty Ltd.

The information contained in this document is subject to change without notice and should not be construed as a commitment by Comfortel Furniture Pty Ltd.

Comfortel Furniture Pty Ltd. assumes no responsibility for any errors that may appear in this document nor does it make expressed or implied warranty of any kind with regard to this material, including, but not limited to, the implied warranties of merchantability and fitness for a particular purpose.

Comfortel Furniture Pty Ltd. shall not be liable for incidental or consequential damages in connection with or arising out of the use of this document and the program material.

PLEASE RETAIN THIS INFORMATION FOR FUTURE REFERENCE

For more information about our products and services, contact us at comfortel.com.au

WARRANTY PERIOD

TERMS AND CONDITIONS. For more information about our warranty, please refer to our website.

PURCHASE DATE

INVOICE NUMBER

NOTE YOUR PURCHASE DATE & INVOICE NUMBER FOR FUTURE REFERENCE